

# Owner's Manual

**D2500**

**D2000**

**D1500**

**D1000**



# **HPA**

# WARNING

1. Read these instructions - All the safety and operating instructions should be read before this product is operated.
2. Retain these instructions - The safety and operating instructions should be retained for future reference.
3. Heed all warnings - All warnings on the appliance and in the operating instructions should be adhered to.
4. Follow all instructions - All operating and use instructions should be followed.
5. Do not use this apparatus near water - The appliance should not be used near water or moisture - for example, in a wet basement or near a swimming pool, and the like.
6. Clean only with dry cloth.
7. Do not block any ventilation openings. Install in accordance with the manufacturer's instructions.
8. Do not install near any heat sources such as radiators, heat registers, stoves, or other apparatus (including amplifiers) that produce heat.
9. Do not defeat the safety purpose of the polarized or grounding plug. A polarized plug has two blades with one wider than the other. A grounding plug has two blades and a third grounding prong. The wide blade or the third prong is provided for your safety. If the provided plug does not fit into your outlet, consult an electrician for replacement of the obsolete outlet.
10. Protect the power cord from being walked on or pinched particularly at the plugs, convenience receptacles, and at the point where they exit from the apparatus.
11. Only use attachments/accessories specified by the manufacturer.
12. Use only with the cart, stand, tripod, bracket, or table specified by the manufacturer, or sold with the apparatus. When a cart or rack is used, use caution when moving the cart/apparatus combination to avoid injury from tip-over.
13. Unplug the apparatus during lightning storms or when unused for long periods of time.
14. Refer all servicing to qualified personnel. Servicing is required when the apparatus has been damaged in any way, such as power supply cord or plug is damaged, liquid has been spilled or objects have fallen into the apparatus has been exposed to rain or moisture, does not operate normally, or has been dropped.
15. Please keep the unit in a good ventilation environment.
16. **WARNING:** To reduce the risk of fire or electric shock, do not expose this apparatus to rain or moisture. The apparatus shall not be exposed to dripping or splashing and that no objects filled with liquids, such as vases, shall not be placed on apparatus.
17. **WARNING:** The mains plug or appliance inlet is used as disconnect device, the disconnect device shall remain readily operable.
18. **Power Sources** – This product should be operated only from the type of power source indicated on the rating label. If you are not sure of the type of power supply to your home, consult your product dealer or local power company. For products intended to operate from battery power, or other sources, refer the operating instructions.
19. **Safety Check** – Upon completion of any service or repairs to this product, ask the service technician to perform safety checks to determine that the product is in proper operating condition.
20. Don't touch conductive parts of output terminals to prevent hazardous electrical shock. The external wiring connected to the terminals requires installation by an instructed person or the used of ready-made leads or cords.
21. This equipment is for commercial & professional use only.
22. This product is in compliance with EU WEEE regulations. Disposal of end of life product should not be treated as municipal waste. Please refer to your local regulations for instructions on proper disposal of this product.
23. To prevent hazardous electrical shock, do not touch the conductive parts of the output terminals.
24. Please locate the apparatus at places nearby power socket for quick power disconnection in emergency.



Protective earthing terminal. The apparatus should be connected to a mains socket outlet with a protective earthing connection.



This lightning flash is intended to alert the user to the presence of non-insulated "dangerous voltage" on the output terminals that may be of sufficient magnitude to constitute a risk of electric shock. The external wiring connected to the terminals requires installation by an instructed person or the used of ready-made leads or cords.



**CAUTION**  
RISK OF ELECTRIC SHOCK  
DO NOT OPEN



**CAUTION:** To reduce the risk of electric shock, do not remove any cover. No user-serviceable parts inside. Refer servicing to qualified service personnel only.



The lightning flash with arrowhead symbol within the equilateral triangle is intended to alert the user to the presence of uninsulated "dangerous voltage" within the product's enclosure that may be of sufficient magnitude to constitute a risk of electric shock.



The exclamation point within the equilateral triangle is intended to alert the user to the presence of important operation and maintenance (servicing) instructions in the literature accompanying this appliance.

**CAUTION:** To prevent electric shock, do not use this polarized plug with an extension cord, receptacle or other outlet unless the blades can be fully inserted to prevent blade exposure.

## Table of Contents

<b>Introduction</b>	<b>2</b>
<b>Front Panel</b>	<b>3</b>
<b>Back Panel</b>	<b>4</b>
<b>Get start</b>	<b>5</b>
<b>DSP Navigation</b>	<b>8</b>
<b>Processing Features</b>	<b>10</b>
<b>Specifications</b>	<b>11</b>
<b>Wiring</b>	<b>12</b>
<b>Block diagrams</b>	<b>13</b>

# Introduction

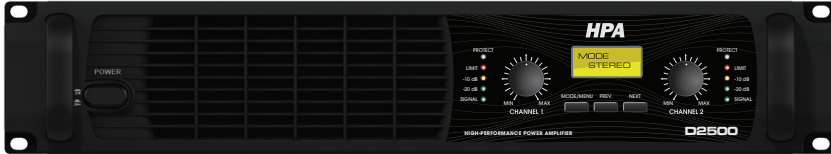

## D1000 / 1500 / 2000 / 2500 Power Amplifier

Congratulations on your purchase of a D series power amplifier, designed for years of high-density Class-D technology that gives reliable. When this amazing amplifier technology is combined with your state-of-the-art switching mode power supply and D class amplifier, these amplifiers provide the highest audio resolution and efficiency.

They are so much more efficient than conventional amplifiers, they run cooler and don't require the massive heat sinks and heavy transformers.

This revolutionary amplifier offers the sonic superiority and great reliability, in an extremely efficient and lightweight design. Advanced protection circuitry allow operation with greater efficiency into any load condition, any power conditions. Thermal limiting circuitry ensures stable operation into loads as below as 2 ohms. This thermal limiting circuitry also ensures powerful sound even in extreme over-load conditions.

# Front Panel

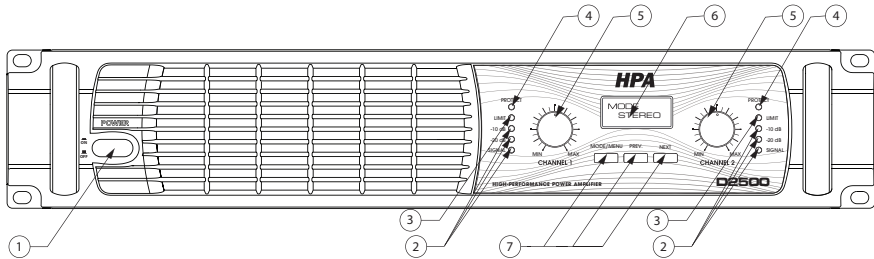

## 1. AC POWER SWITCH

This button triggers the relay that provides power to the amplifier. This power switch will make turn on LCD indicating AC power has been connected to the amplifier.

## 2. SIGNAL LED, -20dB, -10dB.

These LED lights when its channel produces an output signal of -33dB or more (-20dB, -10dB). These LED indicates whether a signal is reaching and being amplified by the amplifier.

## 3. LIMIT

A channel's LIMIT LED will flash at the clipping. If the LEDs are flashing quickly and intermittently the channel is just at the clip threshold. A steady bright means the amp is clip limiting, or reducing gain to prevent clipped waveforms from reaching the speakers. When the amplifier goes to protection mode, this LED will steady bright.

## 4. PROTECT

In the event of abnormal operating conditions, D series have built-in amplifier protection. Under conditions that would normally damage the power amplifier, this LED will illuminate.

## 5. Channel Volume control.

These channel volume controls, located at the front panel, adjust gain for their respective amplifier channels in all mode.

## 6. LCD screen

Back-lit LCD screen allows all DSP configurations.

## 7. MODE/MENU, PREV, NEXT buttons.

Three buttons located under LCD screen that are used to configure and access the integrated processing.

# Back Panel

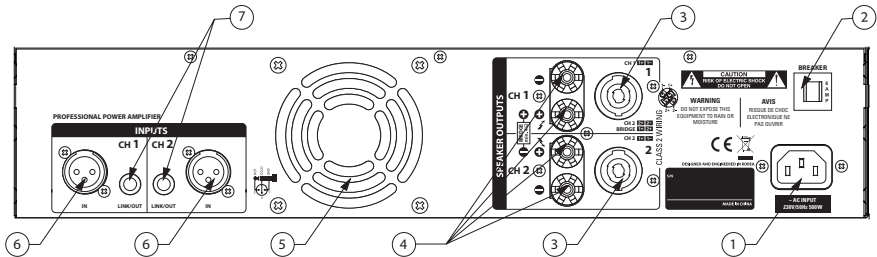

## 1. AC POWER INLET

This is the receptacle for an IEC power cord, which provides AC power to the amplifier.

## 2. CIRCUIT BREAKER

This circuit breaker will trip if there is a fault with the main voltage or if maximum output is exceeded (very highly distorted). Push it in (once only) to restart the amplifier after a short rest period.

## 3. SPEAKER OUTPUT CONNECTORS

These two connectors accept 2-pole or 4-pole Speakon connectors. The channel 1 connector is wired for both channels so it can be used for bridge mode wiring or stereo wiring of two speakers to a single speakon.

## 4. 5-WAY BINDING POST

Use these to connect each channel of the amplifier to 4-ohm or 8-ohm loudspeakers. Be sure to connect the loudspeakers correctly, with the red(+) terminal normally to the positive input of the speaker and black(ground) terminal normally connected to negative input of the speaker.

## 5. FAN

Provide front to back forced airflow for cooling. Make sure that both of front and rear panels are kept free of all obstructions and that cool, fresh air is acceptable at all times.

## 6. BALANCED XLR INPUTS

Connect incoming signals to these balanced XLR connectors, wired as follows : Pin 2 hot, Pin 3 cold, Pin 1 ground. We recommended the use of balanced three-conductor cabling wherever possible.

## 7. 1/4" INPUTS

Balanced 2- 1/4" input connectors are provided (one per channel). Unbalanced two conductor 1/4" plugs can also be inserted into these inputs but you will get better signal quality and less outside noise and hum if you balanced line.

# Get Started

## Stereo Mode

This is the default mode the amplifier is set to from factory. The amplifier is configured the stereo mode.

1. Connect Left / Right signal source to Channel1 and Channel2 using XLR, 1/4" connectors.
2. Connect a speaker to each Channel output using Speakon, 5-way binding post.

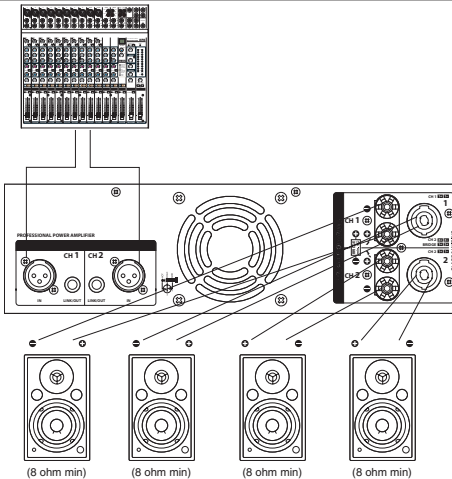
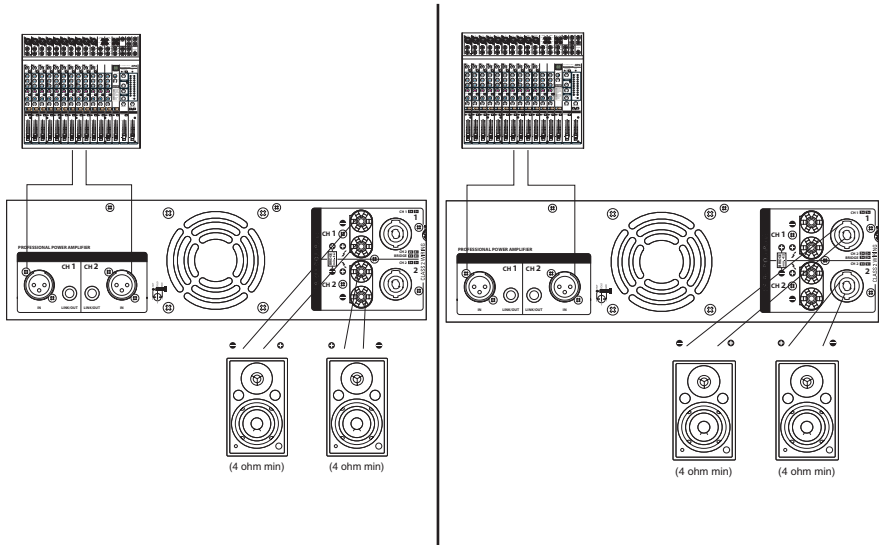

### INPUT Y Mode

INPUT Y Mode delivers input source of Channel 1 into Channel 2 amplifier.

1. Connect signal source to Channel 1 only using XLR, 1/4" jacks.
2. Connect a speaker to each Channel output using Speakon, 5-way binding post.

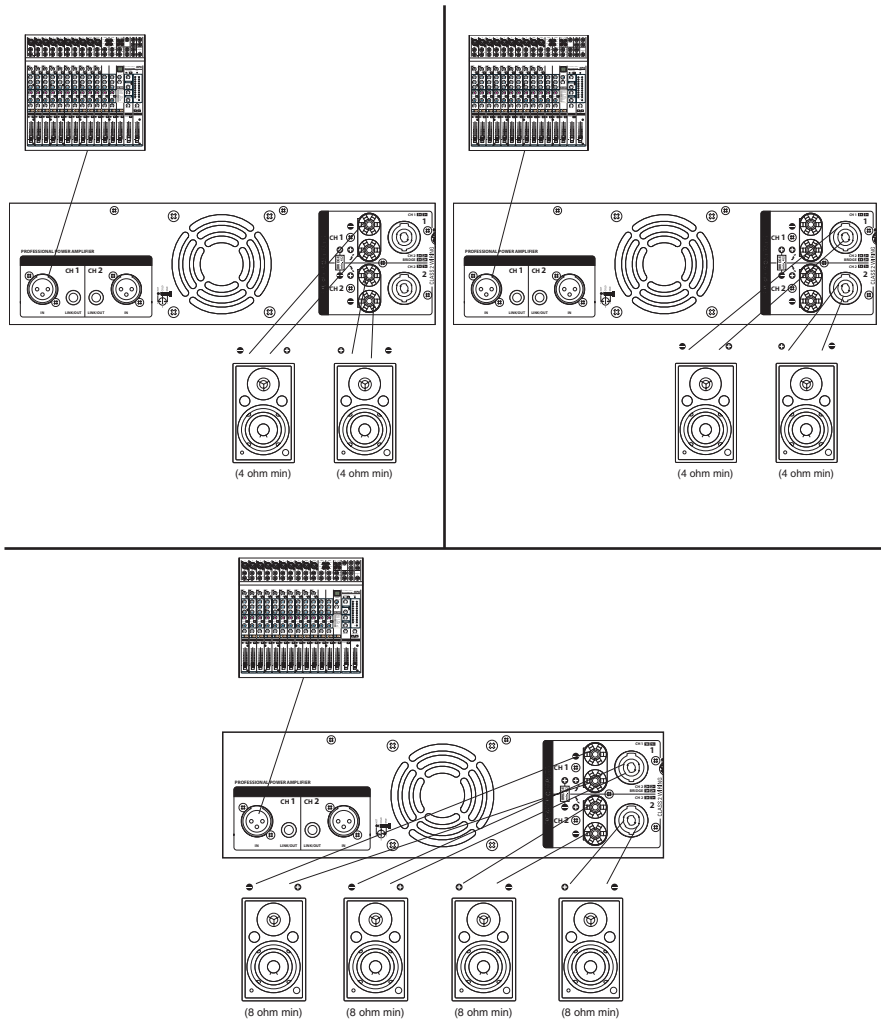

**Bridge Mode**

Bridge Mode elivers the power of both amplifier channels into a single 8 or 4 ohm load.

1. Connect signal source to Channel1 only using XLR, 1/4" jacks.
2. Connect a speaker as below.
  - 2-1. Using Speakon jack : Connect the positive terminal of the speaker to 1+ and the negative terminal to 2+. Plug the connector into the Channel1 Speakon jack only.
  - 2-2. Using 5-way binding post : Connect the positive terminal of the speaker to the positive terminal of Channel1 and the negative terminal of the speaker to the positive terminal of Channel2. Red-Red.

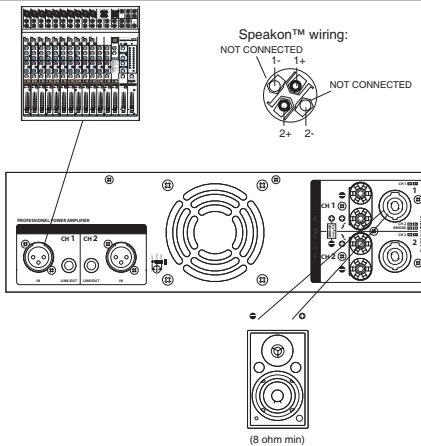
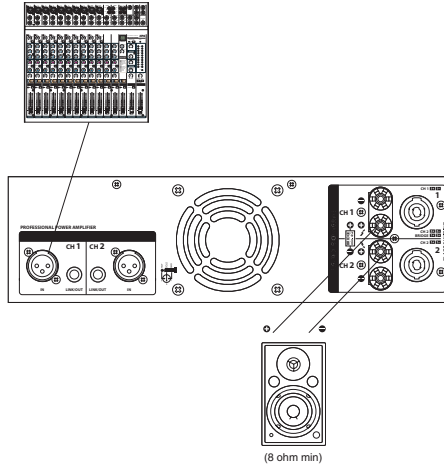

## DSP Navigation

From the DSP window on front panel, you can change settings for several of the amplifier's integrated signal processing features as below flow figure. When you power-on the amplifier for the first time, the LCD screen displays " ". Subsequent power-ons display the preset that was active when you last shut off the amplifier.

The figure below shows the Menu Tree, which is the navigation path of options in the Menu. It shows how you navigate through the front panel and which settings are available from the frone panel. You can press MENU/MODE, NEXT, PREV buttons to make preset what you want to.

# DSP Navigation

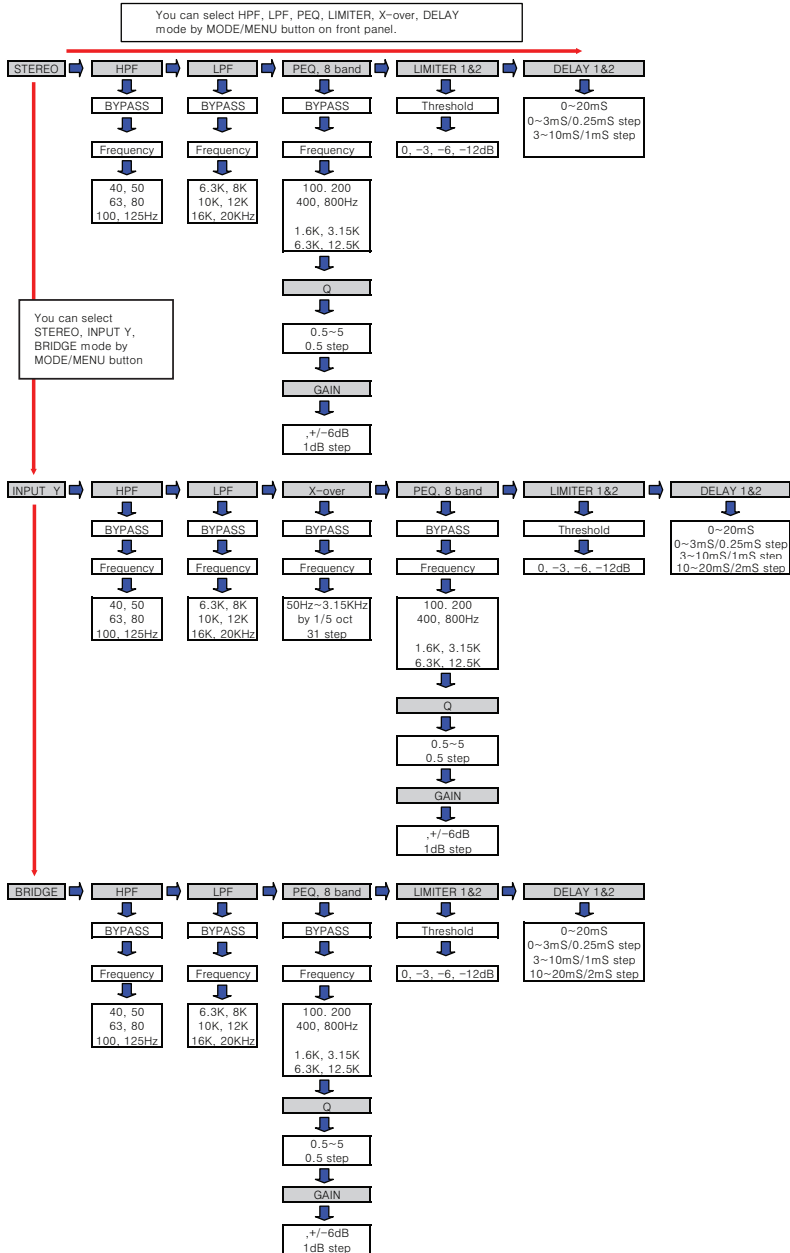

# Processing Features

The D Series amplifiers include a number of integrated processing features which appear on the front panel LCD screen.

## MODE

- \* **Stereo** : In this mode, Channel 1 input signal goes to Channel 1 output and Channel 2 input signal goes to Channel 2 output.
- \* **INPUT Y** : In this mode, the Channel 1 input signal sent to the Channel 1 and Channel 2 output. The Channel 2 input signal is ignored.
- \* **BRIDGE** : In this mode, the power of both amplifier channels are delivered into a single 8 or 4 ohm load.

## MENU

\* **HPF** : This filter reduces unwanted, potential energy-robbing low-end frequencies. Setting an appropriate high-pass filter frequency also helps protect the loudspeaker from damage.

In this MENU, you can set roll-off frequency which are 40, 50, 63, 80, 100, 125Hz.

\* **LPF** : In this MENU, you can set roll-off frequency which are 6.3K, 8K, 10K, 16K, 20KHz.

\* **PEQ, 8BAND** : There are 8 band parametric EQ which are 100Hz, 200Hz, 400Hz, 800Hz, 1.6KHz, 3.15KHz, 6.3KHz, 12.5KHz. We can adjust Q value and gain for boost and cut in this mode. Adjustable Q range is 0.5 ~ 5 by 0.5 step. Adjustable gain range is +/-6dB by 1dB step. We can adjust Q and gain for sound environment.

\* **LIMITER** : LIMITER provides your amplifier and system with higher performance and better protection. There is just one parameter of THRESHOLD for easy set up. We can set up threshold level by 0dB, -3dB, -6dB, -12dB.

\* **DELAY** : Total delay time is 20mS per channel. Adjustable step is that 0~3mS / 0.25mS step, 3~10mS / 1mS step and 10~20mS / 2mS step.

\* **X-OVER in INPUT Y** : X-OVER system provides a variable state Linkwitz-Reley 24dB/oct filter allowing you to choose a point between 50Hz AND 3.15KHz on 1/5th oct centers. The following point are 50Hz, 56Hz, 64Hz, 74Hz, 85Hz, 98Hz, 112Hz, 129Hz, 148Hz, 171Hz, 196Hz, 225Hz, 259Hz, 342Hz, 392Hz, 451Hz, 518Hz, 595Hz, 684Hz, 786Hz, 903Hz, 1.03KHz, 1.2KHz, 1.37KHz, 1.57KHz, 1.8KHz, 2.08KHz, 2.4KHz, 2.7KHz, 3.15KHz.

# Specifications

		<b>D1000</b>	<b>D1500</b>	<b>D2000</b>	<b>D2500</b>
Rate Power (1kHz, THD 1%)	8 $\Omega$ Stereo	215 W	300 W	375 W	440 W
	4 $\Omega$ Stereo	350 W	500 W	650 W	750 W
	2 $\Omega$ Stereo	500 W	750 W	1050 W	1200 W
	8 $\Omega$ Stereo	700 W	1000 W	1300 W	1500 W
	4 $\Omega$ Stereo	1000 W	1500 W	2100 W	2400 W
Input Sensitivity ( 4 $\Omega$ 1kHz )		4 dBu			
Input impedance		30 k $\Omega$ Balanced/15 k $\Omega$ Unbalanced			
Input CMRR ( 1kHz )		> 50 dB			
Frequency Response ( $\pm$ 0.5dB )		20Hz-20 kHz			
Amplifier		CLASS D			
Power Supply		Switching mode power supply			
T.H.D		< 0.03%			
Signal to Noise Ratio		> 100dB			
Damping Factor ( 8 $\Omega$ 400Hz )		>200			
Channel Separation ( 8 $\Omega$ 1kHz )		> 70 dB			
Integrated DSP Processing		Crossover : Frequency Range ; 50Hz-3kHz, 24dB/oct			
		Filters : LowPass & HighPass ( both channels )			
		Limiter ( Channel independent clip limiter )			
		PEQ & Time Alignment			
Power Source		AC 100-240V / 100-240V, 50/60Hz			
Weught (Net)		4.9 kg	4.9 kg	5.2 kg	5.2 kg
Dimensions (W x H x D)		482 x 88 x 280			

Necessary modifications are carried out without notice.

# Wiring

These are several ways to interface the D series amplifier to support a variety of applications. The D series features balanced inputs and outputs, so connecting balanced and unbalanced signals is possible.

## Unbalances 1/4" Connector

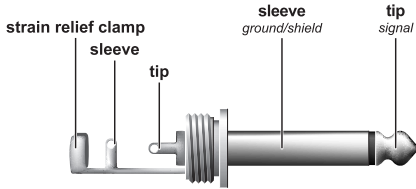

## Speakon® Output Connector

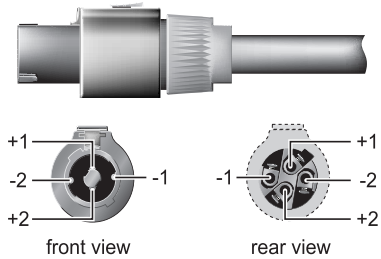

## Balances TRS 1/4" Connector

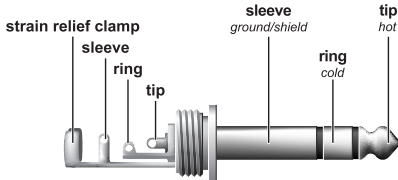

For connection of balanced and unbalanced plugs, ring and sleeve have to be bridged at the stereo plug.

## XLR Balanced Wiring Guide

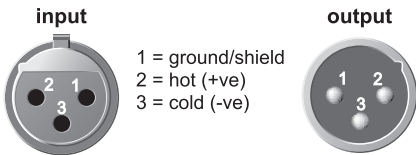

For unbalanced use pin 1 and pin 3 have to be bridged

# Block diagrams

SCHEMATIC DIAGRAM  
MODEL: D1000/1500/2000/2500

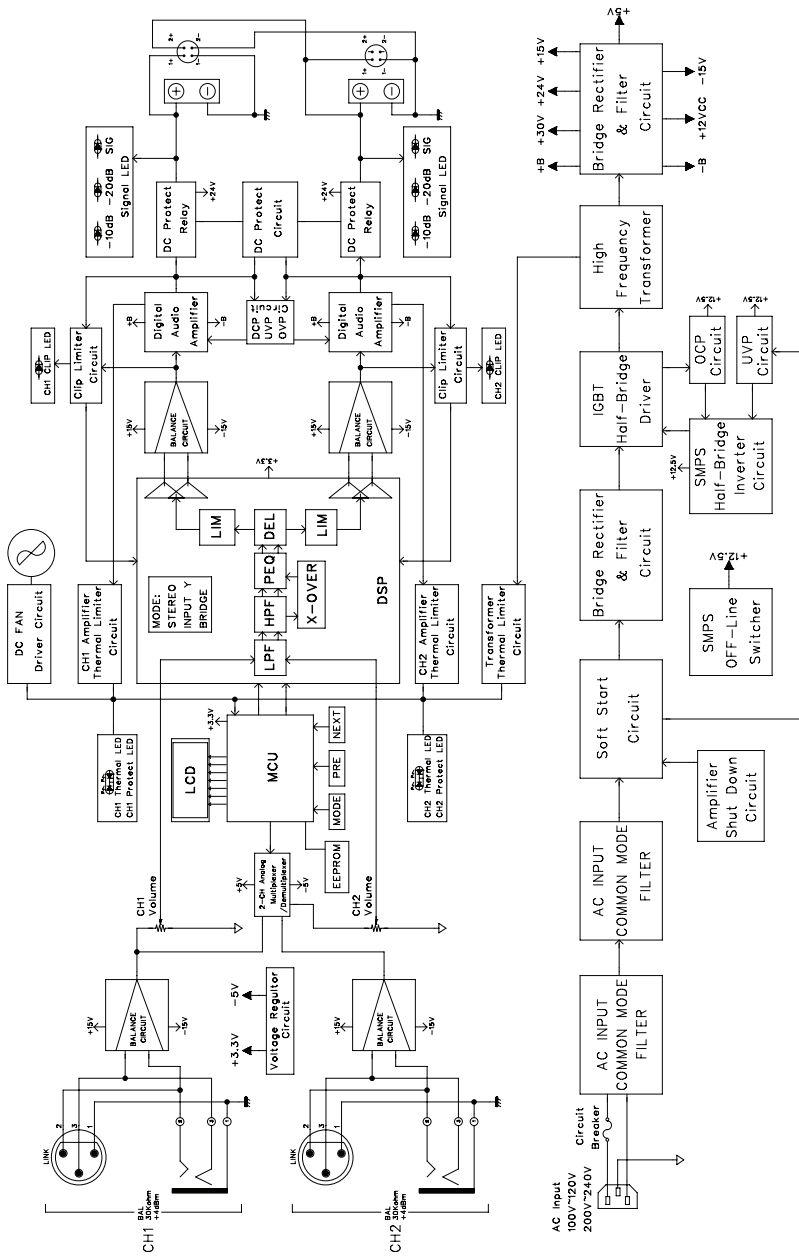

***HPA***